

SECTION **ACC**  
ACCELERATOR CONTROL SYSTEM

A

ACC

C

D

CONTENTS

E

<b>SERVICE INFORMATION</b> .....	2	<b>ACCELERATOR CONTROL SYSTEM</b> .....	3	F
<b>PRECAUTIONS</b> .....	2	Component .....	3	
Precaution for Supplemental Restraint System		Removal and Installation .....	3	
(SRS) "AIR BAG" and "SEAT BELT PRE-TENSIONER" .....	2			G

G

H

I

J

K

L

M

N

O

P

# PRECAUTIONS

< SERVICE INFORMATION >

## SERVICE INFORMATION

### PRECAUTIONS

#### Precaution for Supplemental Restraint System (SRS) "AIR BAG" and "SEAT BELT PRE-TENSIONER"

INFOID:000000003318361

The Supplemental Restraint System such as "AIR BAG" and "SEAT BELT PRE-TENSIONER", used along with a front seat belt, helps to reduce the risk or severity of injury to the driver and front passenger for certain types of collision. This system includes seat belt switch inputs and dual stage front air bag modules. The SRS system uses the seat belt switches to determine the front air bag deployment, and may only deploy one front air bag, depending on the severity of a collision and whether the front occupants are belted or unbelted. Information necessary to service the system safely is included in the "SUPPLEMENTAL RESTRAINT SYSTEM" and "SEAT BELTS" of this Service Manual.

#### **WARNING:**

- To avoid rendering the SRS inoperative, which could increase the risk of personal injury or death in the event of a collision which would result in air bag inflation, all maintenance must be performed by an authorized NISSAN/INFINITI dealer.
- Improper maintenance, including incorrect removal and installation of the SRS, can lead to personal injury caused by unintentional activation of the system. For removal of Spiral Cable and Air Bag Module, see the "SUPPLEMENTAL RESTRAINT SYSTEM".
- Do not use electrical test equipment on any circuit related to the SRS unless instructed to in this Service Manual. SRS wiring harnesses can be identified by yellow and/or orange harnesses or harness connectors.

#### PRECAUTIONS WHEN USING POWER TOOLS (AIR OR ELECTRIC) AND HAMMERS

#### **WARNING:**

- When working near the Air Bag Diagnosis Sensor Unit or other Air Bag System sensors with the ignition ON or engine running, DO NOT use air or electric power tools or strike near the sensor(s) with a hammer. Heavy vibration could activate the sensor(s) and deploy the air bag(s), possibly causing serious injury.
- When using air or electric power tools or hammers, always switch the ignition OFF, disconnect the battery, and wait at least 3 minutes before performing any service.

# ACCELERATOR CONTROL SYSTEM

< SERVICE INFORMATION >

## ACCELERATOR CONTROL SYSTEM

Component

INFOID:000000002955369

A

ACC

C

D

E

F

G

H

I

J

K

L

M

N

O

P

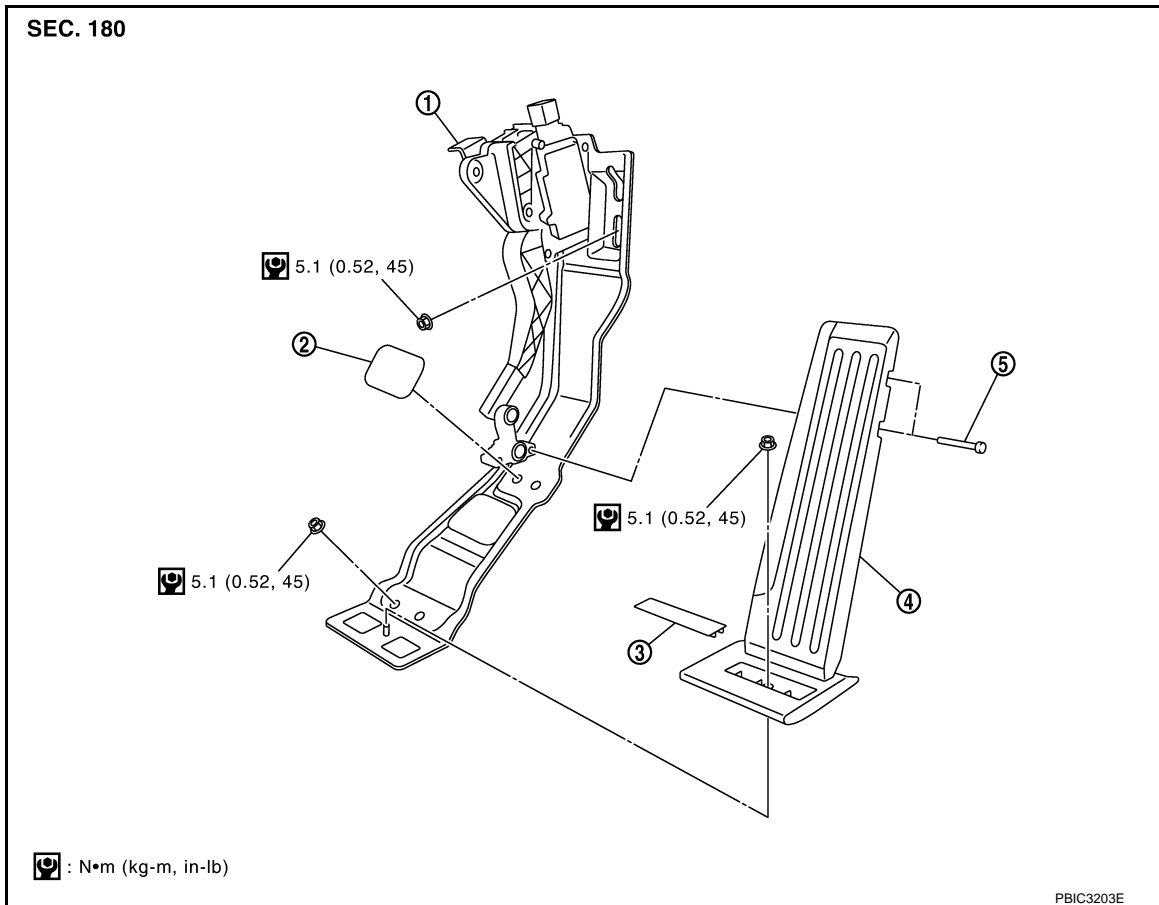

1. Accelerator pedal bracket and lever assembly
2. Accelerator pedal stopper cover
3. Cap
4. Accelerator pedal pad
5. Pin

## Removal and Installation

INFOID:000000002955370

### REMOVAL

1. Disconnect accelerator pedal position sensor harness connector.
2. Remove front kicking plate and dash side finisher. Refer to [EI-48](#).
3. Remove the cap and the inside mounting nut, and then disassemble the accelerator pedal pad from the floor carpet.
4. Press the pin (1) with long-nose pliers and pull them out in the direction shown by the arrow (←). Then remove the accelerator pedal pad (2).

### CAUTION:

Never disengage the part (the link) other than pins.

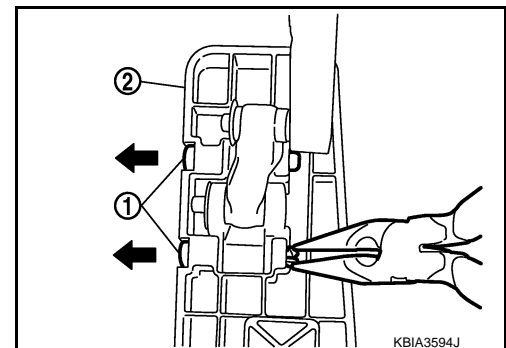

5. Remove accelerator pedal stopper cover.

# ACCELERATOR CONTROL SYSTEM

## < SERVICE INFORMATION >

---

6. Pull up the floor carpet.
7. Remove mounting nuts of accelerator pedal bracket.
8. Remove accelerator pedal bracket and lever assembly.

**CAUTION:**

- **Never disassemble accelerator lever. Never remove accelerator pedal position sensor from accelerator lever.**
- **Avoid impact from dropping etc. during handling.**
- **Be careful to keep accelerator lever away from water.**

## INSTALLATION

Installation is the reverse order of removal.

## INSPECTION AFTER INSTALLATION

- Check accelerator pedal moves smoothly within the whole operation range when it is fully depressed and released.
- Check accelerator pedal securely returns to the fully released position.
- For the electrical inspection of accelerator pedal position sensor, refer to the following:

- VQ35DE

[EC-550.](#)

- VK45DE

[EC-1188.](#)

**CAUTION:**

When harness connector of accelerator pedal position sensor is disconnected, perform "Accelerator Pedal Released Position Learning". Refer to [EC-82, "Accelerator Pedal Released Position Learning"](#) (VQ35DE) or [EC-706, "Accelerator Pedal Released Position Learning"](#) (VK45DE).